

# Window or Light Skylight Motorization System Installation Instructions



Made in USA





**Danger: To help prevent severe personal injury or death:**

- Read and understand instructions completely before beginning installation.
- Wiring must be installed by a qualified electrician according to local and National Electrical Codes (N.E.C.)
- Disconnect main power before beginning installation! Verify that power is OFF at the main breaker or fuse panel by testing with a voltage meter that you know is working correctly.
- Connect power only after motor connections and settings are verified.
- This equipment does not provide a method to shut off power, and should be connected to a dedicated breaker or fused power circuit capable of providing 1 amp at 120 VAC of power per window unit.
- The screen interlock MUST be correctly installed and is a required part of the power window system. It is intended to help prevent injury that could result from reaching into the window area during operation. The correct installation of the screen interlock is the responsibility of the installer. (The screen interlock is not required on windows and skylights installed more than 8 feet above the floor.)
- Do not allow children to operate the wall push buttons or remote control transmitter(s).

**Additional Safety Guidelines**

- When connecting the Sentry II system to accessories, read the installation instructions supplied with each accessory before beginning installation.
- The Sentry II system must **not** be used on windows intended to meet egress codes.
- The Sentry II system is intended for indoor use only, with screens in place.
- Save ALL instructions.
- Installer – please be sure to give ALL instructions to the homeowner once installation is complete.

# Table of Contents

<b>Preparation</b>	<b>What you should know before starting.... 4</b>
<b>Getting Started</b>	<b>Parts List ..... 5</b> <b>Planning..... 6</b>
<b>Set Up</b>	<b>Inspect Windows..... 7</b> <b>Battery Backup ..... 8</b>
<b>Installation</b>	<b>Motor Installation ..... 9</b> <b>Controller Installation ..... 14</b> <b>Main Wiring Diagram ..... 17</b>
<b>Operation</b>	<b>Normal Operation..... 20</b>
<b>Accessories</b>	<b>Rain Sensor ..... 21</b> <b>HPI..... 22</b> <b>Power Blind Control ..... 23</b>
<b>Troubleshooting</b>	<b>Common Problems ..... 24</b> <b>System Reset ..... 26</b> <b>Service ..... 27</b> <b>Status Light Code ..... 28</b>
<b>Additional Info</b>	<b>Control Box Cut-Out Template ..... 29</b> <b>Regulatory Compliance..... 30</b>

## What You Should Know Before Starting

**Supply Voltage Note:** The supply voltage range for the Sentry II power window system is very flexible to accommodate supply voltages available from many different countries. The input (supply) voltage range is 90 to 264 VAC at a frequency range of 47 to 440 Hz. For practical purposes, the supply voltage referenced in this document is 120 volts at 60 Hz commonly used in the United States.

**Operating Environment:** The control unit must be located in a dry environment which includes protection from condensation. The operating temperature range must be maintained between 140° F (60° C) to -5° F (-20° C).

**Be sure the motor system will fit in your application:** The Sentry power window system is intended to fit onto casement, awning and skylight hardware manufactured by AmesburyTruth only. In many cases you will be able to identify our hardware by our logo (🏠) somewhere on the hardware. When in doubt, the best way to tell is if the spline adaptor fits onto the operator stem in place of the crank handle – see Motor Installation step 2 .

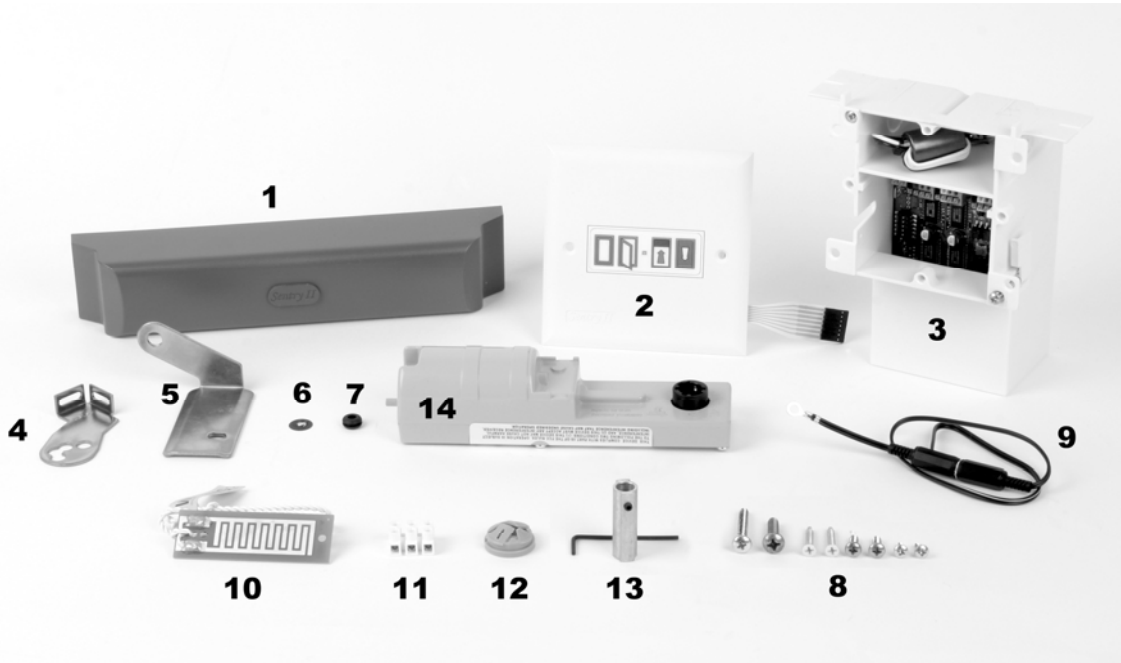
The Sentry II power window will not work in the following applications:

- Fitted to any type of jalousie window
- Fitted to any type of door
- Fitted to any type of cable controlled window system - Such as those manufactured by Clearline or Ultra-Flex
- Fitted to any type of in-swing window
- Fitted to any type of manual skylight hardware manufactured by Velux or Roto

**Any use of the Sentry II power window system not approved by AmesburyTruth is at the user's own risk.**

**Be sure the motor system is compatible with your application:** It is important to understand that the design parameters of the Sentry II power window system are predicated on a properly functioning manual window system. This includes the rotary operators and hinges installed on the window. It is the responsibility of the window manufacturer and/or the window specifier to insure the window size and weight fall within the specifications of the manual hardware system installed on the window. If the window size and/or weight fall outside of the hardware specifications, the motor system may not function properly. If the window carries an AAMA (American Architectural Manufacturers Association) label chances are the window system meets all hardware requirements. However, if the window does not carry an AAMA label you may want to contact the window manufacturer to verify the windows have been manufacturer within the hardware manufacturer's specifications - especially if the window size is unusually large and/or of unusual proportions.

# Getting Started



## Parts list

## Part number

1. Motor Cover	12490.XX (not part of kit)
2. Control unit cover plate	12488
3. Wall mounted control unit	12592
4. Mounting bracket – Window *	Parts 4 thru 13 are in hardware pack 12492
5. Mounting bracket – Skylight **	
6. Push on fastener	
7. Isolation grommet	
8. Screws	
9. Screen interlock	
10. Rain sensor	Replacement part #22123
11. Terminal block	
12. Strain relief	
13. Spline adapter and wrench	
14. Motor unit	12547.00.0001
Installation instructions (not pictured)	90063

\* Window bracket may look slightly different.

\*\* Skylight bracket is not included with all kits.

XX Indicates a color selection

### Note:

- No wire is included. See wiring diagram on page 17 for wire requirements.

# Planning

---

**Important:** *If you are not the homeowner, it is important to contact the homeowner and discuss how they want to control a group of windows and/or skylights. It may be very difficult to change the installation to meet the homeowner's desires once installation is complete.*

## **Please consider:**

- If installing more than one power window system, each motorized window **must** have its own control unit. If there are multiple windows and/or skylights installed and it is desired to have a single control point for all windows and skylights, the wireless RF remote control will give you this option. Since the remote control uses RF communication technology it is not restricted to line-of site limitations.
- The control unit will give convenient wall mounted control only for the window connected to it. If the wall mounted control is not intended to be the primary means of control you may want to consider mounting it in a remote, out-of-the-way location.
- All Sentry II control units are Remote Control enabled. This allows you the convenience of adding an optional remote control at any time.
- If you are installing the motor system onto a window that has manual locks be sure the locks are unlocked manually before attempting to open. Power sash locks are an available option for some windows.
- The Sentry II power window system does not have manual override in case of a power outage. If it is important to be able to close the windows without power, consider installing a battery back-up system.
- There are a number of other control options available:
  - **Remote Control Has Built-in Thermostat** - For those applications where it is desirable to open and close your windows or skylights based on temperature, please be aware that the optional remote control has a built-in thermostat. Just set the temperature and place the remote in the area where you want the temperature controlled.
  - **Rain Sensor** - A rain sensor comes standard with each unit. If you choose to install the rain sensor option, each control unit needs a separate rain sensor. Consult main wiring diagram for wiring requirements if used. List max dist.
  - **Power Sash Locks** - The optional power sash locks require additional wires to be run from the control unit to the window. Consult main wiring diagram for wiring requirements if used.

- **Power mini blinds** - The Sentry II control unit is capable of controlling power mini blinds (supplied by others) in addition to the window motor and sash locks. See page 23 for additional information. Consult main wiring diagram for wiring requirements if used.
  - **Window status feedback** - The Sentry II control unit is capable of providing window position feedback (open or closed). See page 23 for additional information. Consult main wiring diagram for wiring requirements if used.
  - **Integrated control with other control systems** - The Sentry II power window system can be integrated with other automated control systems. Some examples are home automation systems, thermostats and security systems. See page 22 for additional information. Consult main wiring diagram for wiring requirements if used.
- Each control unit requires 1 amp of power at 120 VAC.
  - Plan your wiring routes carefully. Low voltage wires must not be run parallel to high voltage wires. Be sure to use shielded, twisted pair wiring in electrically noisy environments.

## Set Up

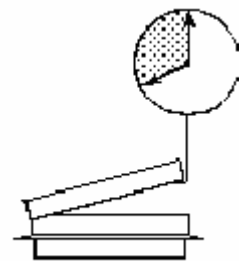
### Inspect Windows

---

The windows and/or skylights must operate correctly and smoothly. Lubrication or cleaning of hardware may be required. This motor system will not operate correctly if the manual hardware is not functioning properly.

#### Important Skylight Information:

- When installing the Sentry II motor on a skylight, the skylight lid must weigh less than 40 lbs. at the chain. A hand crank should be used to verify the skylight operates smoothly.
- When installing on a skylight, the motor system will only fit the angle drive model manufactured by AmesburyTruth shown in step 3. Verify the skylight operator you have looks like the one shown in step 3.



Skylight lid must weigh less than 40lb (18 kg) at the chain

## Battery Backup

---

Battery backup should be used to supply emergency power when operation of the power window system must be maintained in the event of a power outage. (**Please note:** A battery back-up is *not* required to provide memory back-up for the Sentry II system.)

AmesburyTruth recommends the use of a UPS (uninterruptible power supply) as a battery backup. They are widely available through a variety of retail and commercial outlets and are primarily used to supply emergency backup for computer equipment.

To determine the proper VA rating for a UPS, take 50 watts and multiply by the number of windows and/or skylights to be backed up by a given UPS. Below is a list of the manufacturers who produce uninterruptible power supplies which we have approved as compatible with our power window systems.

Powerware  
Forum III  
8609 Six Forks Road  
Raleigh, NC 27615  
(800) 554-3448  
(919) 872-3020  
[www.powerware.com](http://www.powerware.com)

American Power Conversion  
132 Fairgrounds Road  
West Kingston, RI 02892  
(800) 788-2208  
(401) 789-5735  
[www.apcc.com](http://www.apcc.com)

Tripp Lite  
1111 West 35th Street  
Chicago, IL 60609  
(773) 869-1111  
[www.tripplite.com](http://www.tripplite.com)

Minuteman (brand)  
1455 LeMay Drive  
Carrollton, TX 75007  
(800) 238-7272  
(972) 446-7363  
[www.minuteman-ups.com](http://www.minuteman-ups.com)



# Installation

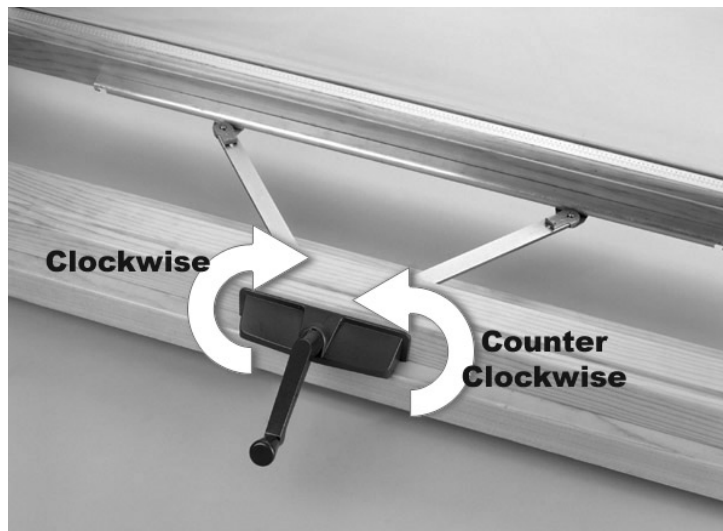
## Motor Installation

**Note:** Window operators are usually mounted to the bottom sill of the window. Occasionally the operator will be mounted on the side jamb of an awning or casement window and also occasionally to the head of a hopper window. These are all acceptable applications provided the window opens and closes smoothly throughout its full range of motion. Be sure the motor system is mounted securely to the window in these applications.

### 1. Test hand crank

**a. Determine the direction of hand crank rotation to open the window** as either Clockwise or Counter Clockwise (when facing the window operator).

**b. Circle the direction to OPEN below.** (This information will be needed for proper system setup in Step 5.):



**Note:** The window or skylight can be in any position while installing the Sentry II motor. However, leaving the window or skylight partially open is helpful in testing system operation. When power is supplied to the motor for the first time, the control system is programmed to close the window. A closing window upon power-up will therefore confirm that the motor is receiving power and wiring polarity is correct. If the window is closed during motor installation, a short noticeable hum will confirm that the window is receiving power.

## 2. Install adapter

---

Before installing the spline adapter determine how the adapter should be applied to the type of window operator that you have.

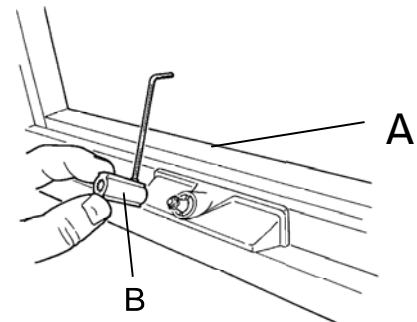
If your window operator is similar to the picture shown below (some operators may have the worm on the other side of the operator case) please switch the set screw to the hole at the opposite end of the adaptor before installing on the operator shaft. For all other operators, apply the adapter as it was shipped to you.



If the operator looks similar to the one shown on the left please move the set screw from the hole that it was installed in for shipping to the open hole at the opposite end of the adaptor

After installing the spline adapter (B) onto operator shaft, tighten set screw with wrench (A).

**NOTE:** Be sure the set screw is fully seated into the operator shaft groove.



## 3. Choose wire location

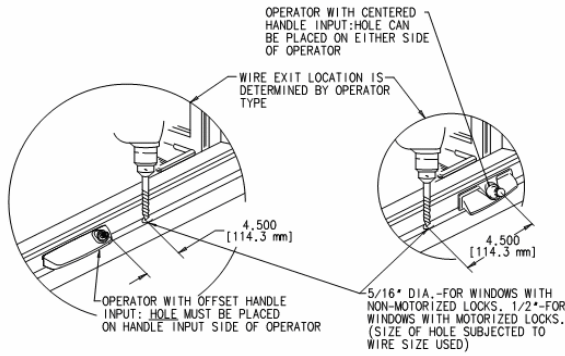
---

**Plan wire exit location on window for**

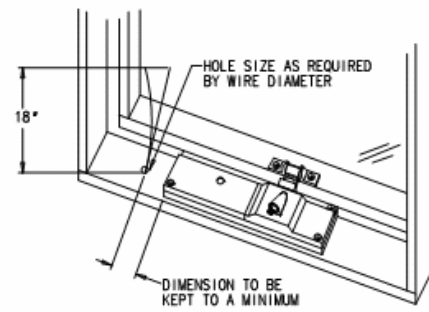
- **Operator motor**  
See figure 3a below for casement and awning windows and Figure 3b for skylights

**Note:** Be sure the window width will accommodate the motor width. See Fig.s 3c & 3d below for finished dimensions.

- **Power sash lock (if used)**  
Consult power sash lock installation instructions
- **Power mini blinds (if used)**  
Consult power mini blind installation instructions

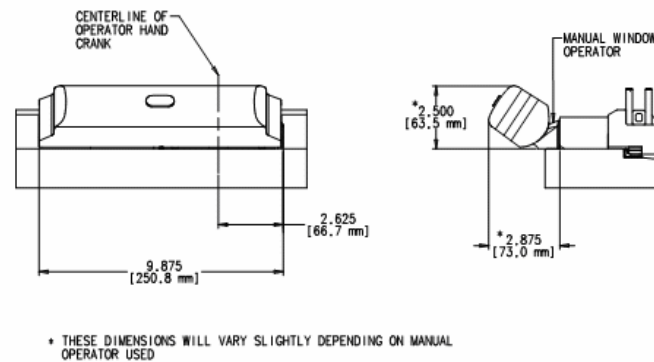


**Figure 3a**



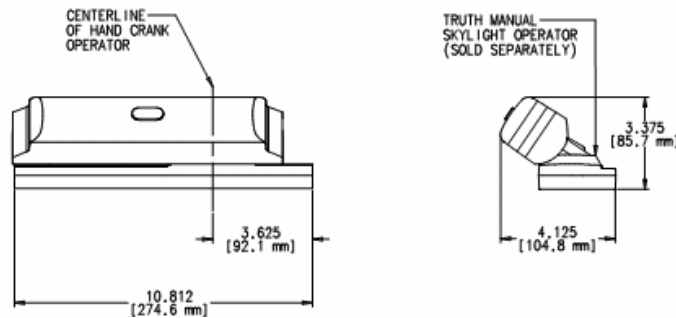
**Figure 3b**

**Note:** The placement information above are guidelines only. In some cases it is better to do a trial fit of the motor onto the operator. Hold the motor square and check both sides while looking for interference between the motor housing and operator housing.



**Figure 3c**

Finished dimensions of motor system applied to a casement or awning window.



**Figure 3d**

Finished dimensions of the WLS motor system applied to a skylight window.

## 4. Mount the motor

- a. Slide motor over spline adapter (B).
- b. Insert the isolation grommet (D) into the mounting bracket where it best lines up with the motor mount post.

*Note: If a number of mounting positions are provided by the bracket, use the one which provides the best alignment with the window frame.*

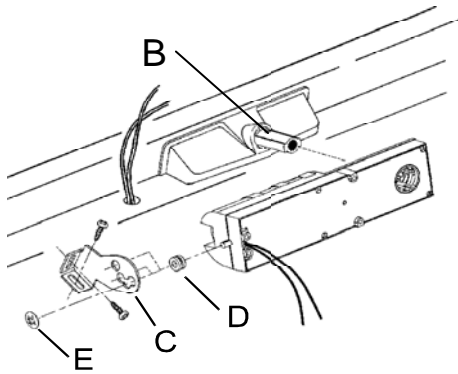
- c. Secure motor with bracket (C).

*Note: In window applications two screws should be used when mounting the bracket (C) to wood or plastic window frames.*

- d. Slide the push-on fastener (E) over the motor post to secure the motor to the bracket and window casing.

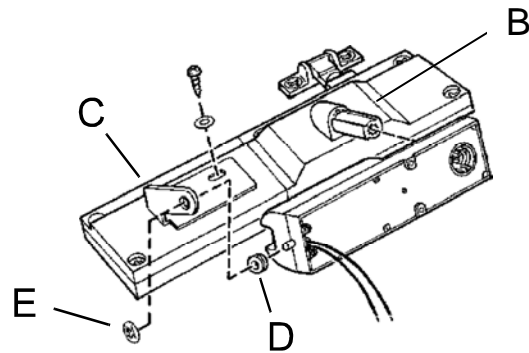
*Warning: The push-on fastener is required for safety. Failure to install the fastener (E) can cause the motor to become detached and fall from window.*

### Window Mount



Sheet metal screws: (2) #8 x 5/8" Ph PH

### Skylight Mount

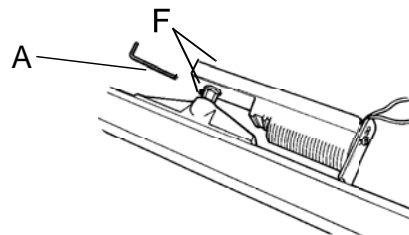


Machine screw : (1) #12-24 x 1" Ph PH

## 5. Align and tighten collar

Align motor to window and tighten set screw in black plastic alignment collar (F) with wench (A).

*Warning: Do not over tighten. Damage will occur to alignment collar if it is tightened excessively.*

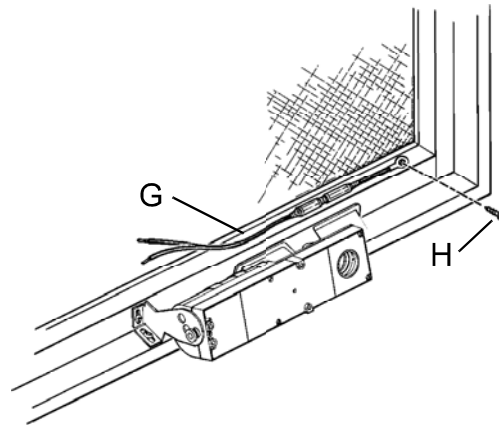


## 6. Install screen interlock!

---

Install screen interlock (G) to the face of the screen frame as shown using the supplied pan head screw (H). Refer to Main Wiring diagram for connection information.

**WARNING:** The screen interlock must be installed on windows or skylights less than 8 ft from the floor. It is intended to prevent personal injury and/or window damage during operation



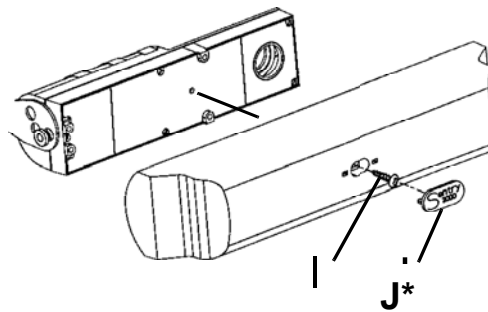
Self threading machine screw: #6-32 x 3/8" Ph PH

## 7. Secure wires and \*install cover

---

- a. Connect motor wires per wire diagram (see page 17) and secure with tape.
- b. Install the motor cover using the 6X3/8 PH screw (I) found under cover button (J).

\* **WARNING:** Use of a longer screw ( ) will damage the motor and void the warranty Use only the screw provided for the motor cover (No. 6-32 X 3/8 Phillips pan head machine screw).



# Controller Installation

## 1. Prepare wall for control unit

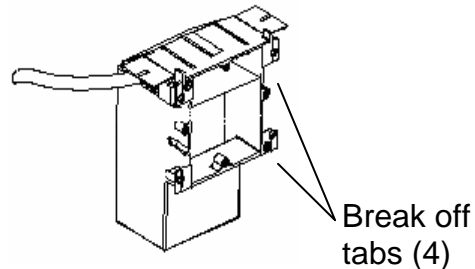
**Note:** A control unit is required for each motorized window. Connecting two or more window motors to one control unit will overload and damage the control unit and void the warranty. Multiple windows can be controlled from a single control point via the optional RF remote control.

**Important:** The control unit is supplied with a protective cardboard shield to protect the delicate control circuits from construction debris during the “rough-in” building phase. Depending on the severity of construction debris expected at the construction site, additional shielding may be required. Sealing the unit with duct tape or some other means until the final wiring phase may be required.

If the install location already has a finished wall with unexposed studs, jump ahead to page 15 and follow steps for “Finished Wall.”

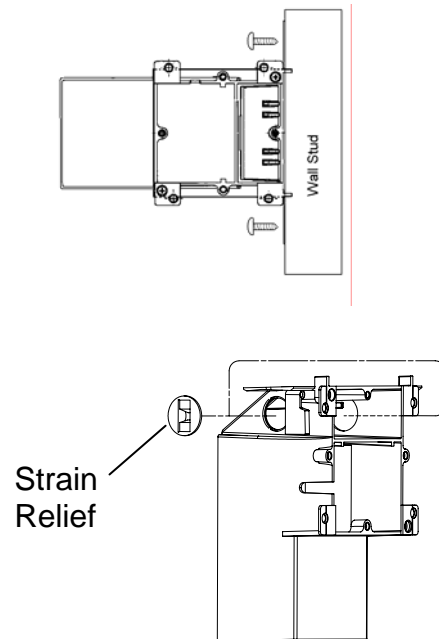
### Open Wall: Step 1

**Locate the desired mounting location for the wall control unit. Mount control box onto the selected wall stud with screws** (not included) at the desired height. Using the template provided on page 29, mark and cut the prescribed hole in wall board for the intended application.



### Open Wall: Step 2

**Route and install wires** - Route low voltage wires from motor location (including any accessory wires, such as rain sensor, power blind, etc...) into control switch opening. (See main wiring diagram on page 17 for complete wiring specifications.) Route appropriate high voltage wire and select an inlet on control box which works with the selected orientation. Remove knock-out and install strain relief provided. Pull 120 VAC wiring into control box through strain relief.

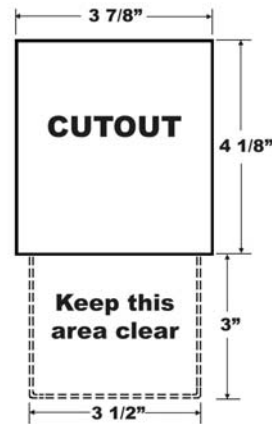


Skip “Finished Wall” steps 1 and 2. Advance to page 16.

## Finished Wall: Step 1

**Locate the desired mounting location for the wall control unit.** Verify the location of interior wall studs before selecting the mounting orientation of control box.

Using the template on page 29 of this instruction booklet, mark and cut wall opening. (Cutout size is 3 7/8 inches Wide X 4 1/8 inches High) Note that a portion of the wall box is hidden inside the wall cavity, and that the box and wall plate can be mounted in any direction required.



Use template located on page 29 to mark cutout location and cut as required. Orientation can be rotated if desired

## Finished Wall: Step 2 Install Control Box

a. **When installing the box after the wall is finished the mounting wings should be cut off and discarded.**

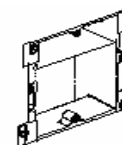
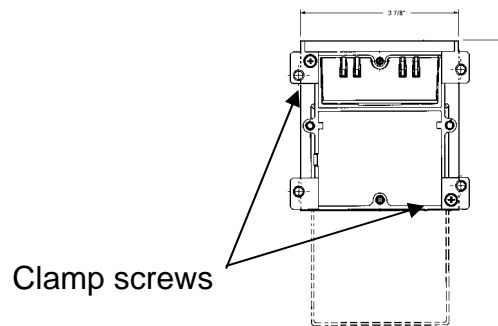
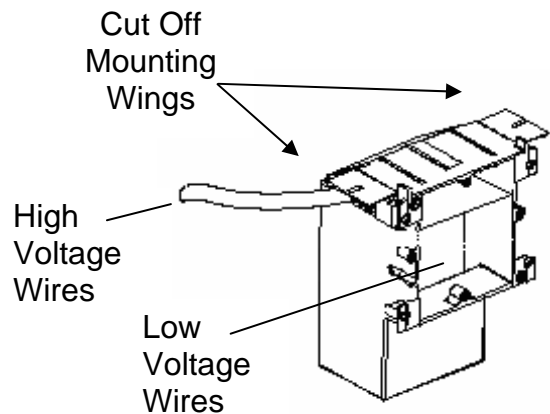
b. **Insert control box into wall opening.**

c. **Secure box to wall by tightening clamp screws.**

The wall clamps engage the wall automatically as the screws are tightened.

d. **Route low voltage wires from motor location (including any accessory wires, such as rain sensor, power blind, etc...) into control switch opening.**

See main wiring diagram on page 17 for complete wiring specifications. Route appropriate high voltage wire and select an inlet on control box which works with the selected orientation. Remove knock-out and install strain relief provided. Pull 120 VAC wiring into control box through strain relief.



Wall Box Installed.

**Danger:** Power supplied to high voltage (120 VAC) wiring should be disconnected at main breaker panel or through other means. This motor control will need 1 amp of current at 120 VAC.

**Note:**

- Installation must meet local and national electrical codes.
- Refer to main wiring diagram for wire size and type requirements.
- Plan your wiring routes carefully. Low voltage wires must not be run parallel to high voltage wires.
- Be sure to use shielded, twisted pair wiring in electrically noisy environments.

## 4. Connect Wires per wire diagram

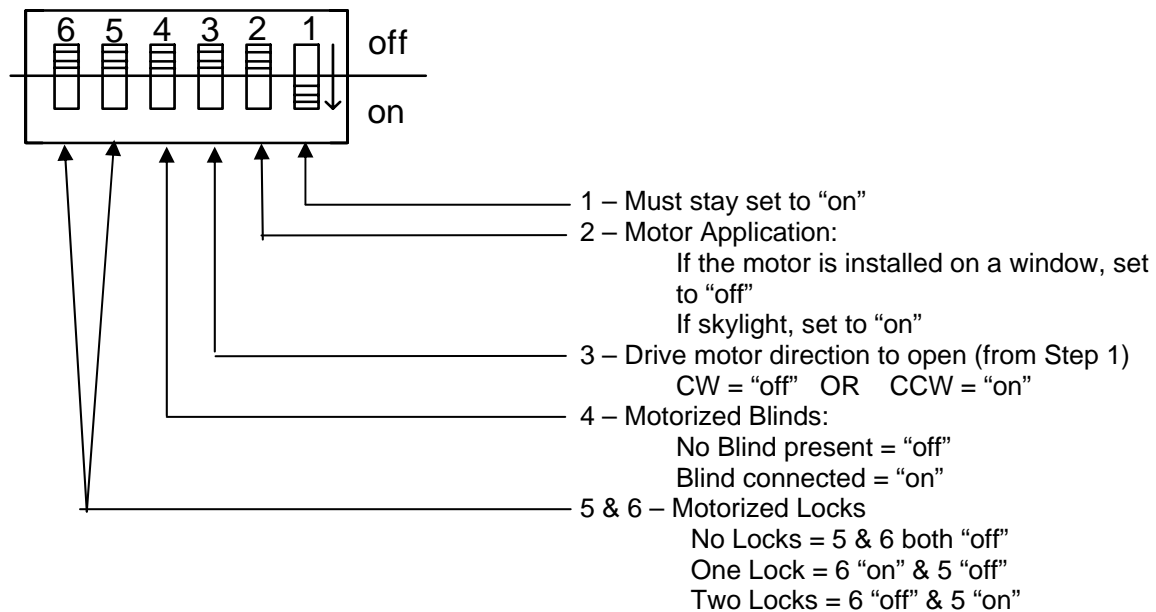
Remove protective cardboard shield. Connect low voltage wires for operator motor and all accessories to the control unit as diagramed on the main wiring diagram (page 17). See terminal blocks 1 thru 5. (Do not apply power until step 7!)

**Note:**

1. Terminal blocks are rated for 16 to 20 gauge solid core wire. If wire runs are such that wire sizes exceed 16 gauge, wire must be spliced down to a 16 to 20 gauge wire before connection to terminal blocks. Keep reduced wire size length to a minimum length. Use solid core wire only for connection to the control unit! Do **not** use stranded wire.
2. Install and connect optional power sash locks at this time if used. Consult installation instructions supplied with lock for proper installation.

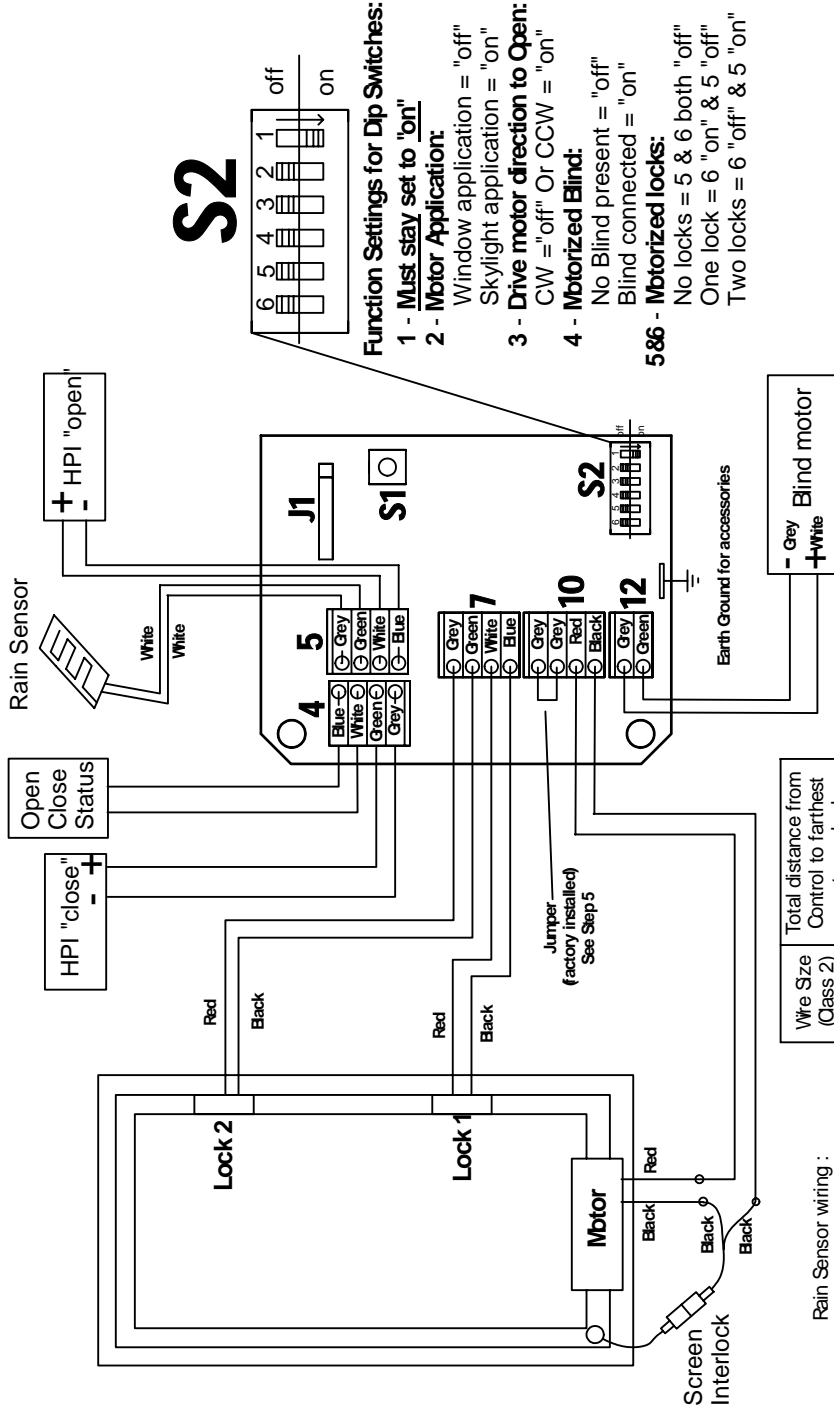
## 5. Set Function Dip Switches

The purpose of setting the dip switches is to properly configure the electronic control system to the type of window and window accessories to be controlled. (See S2 on wire diagram)



**Note:** Dip switch settings must be made with 120 volt supply disconnected.





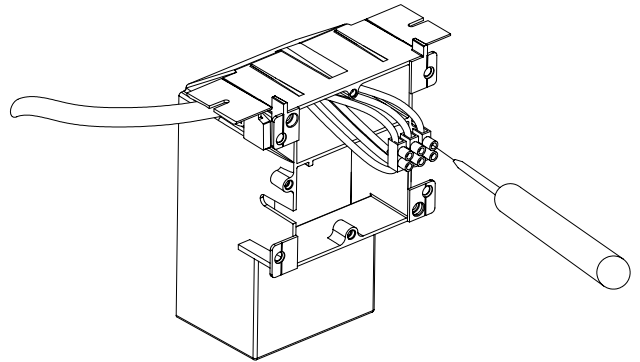
# Main Wiring Diagram

## 6. Connect power wires

---

Connect supply voltage wires (120 VAC) to the wire harness and connector as shown.

**Danger:** to avoid possible electric shock power must be shut off at the main breaker until installation is complete.

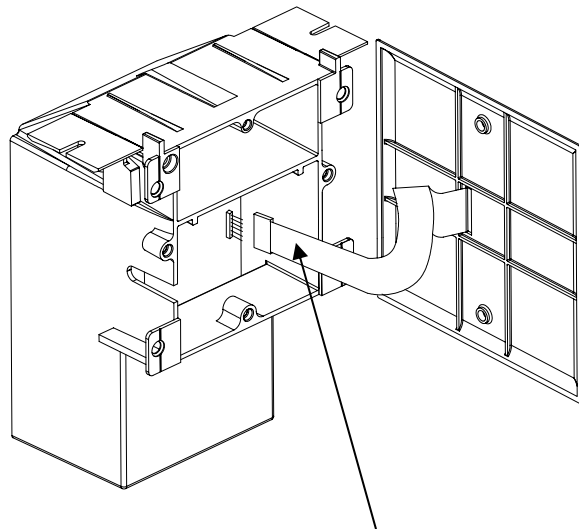


## 7. Plug in and install cover plate

---

Plug in the ribbon cable from the wall plate onto control board (See No. J1 on main wiring diagram, page 17)

**Note:** Orientation of plug is critical to correct operation of wall switch and LED indicators. See note in adjacent diagram.



Ribbon Cable has a shiny side with silver traces and a dull side with green traces. Install with dull side (green traces) facing towards you as shown.

**Helpful Hint:** The cover plate is only available in one configuration and color. The cover plate can however, be painted or wall paper can be applied to change its appearance.

## 8. Apply power

---

### Apply power to the control unit

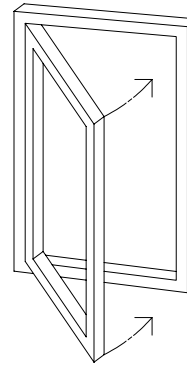
**Note:** Upon power-up the window **should close**. (If window is closed, motor will momentarily hum.)

If the window opens refer to the window crank direction in step 1 and dip switch settings in step 5.

- Disconnect power
- Change dip switch 3 on S2 (Refer to step 5.)
- Reapply power

The window should now close.

**Note:** Do not disconnect power while the window motor is running.



## 9. Program remote control\*

---

If optional remote control was purchased, it can now be programmed to the control unit. Refer to set-up instructions included with the remote control.

\*If the installation does not include a remote control, skip to step 10.

## 10. Establishing operating memory

---

Press "Open" button.

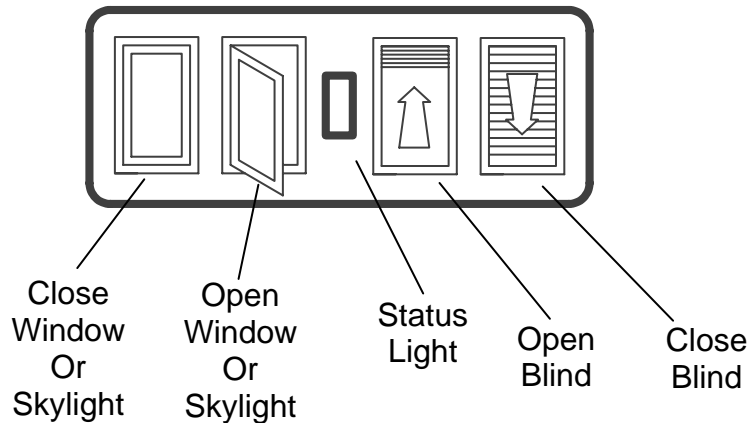
Please note:

- Upon pressing the open button for the very first time after original power up, the unit will automatically run through an initialization cycle, fully opening and closing the window (this may take up to 3 minutes depending on application).
- During this time the switch face plate will display a "Red" LED.
- This cycle is necessary for the unit to establish its operating parameters which will be stored in permanent memory.
- Once permanent memory is established it is unaffected by loss of power of any duration.

# Normal Operation

**Note:** If the window has manual locks the window must be unlocked before motorized operation.

## Buttons located on wall switch:



## To open:

- Press “Open” on either the wall switch or the remote control to fully open the window. If motorized locks are present they will function as part of the window by unlocking and locking automatically.

**Note:** The full open position of a window will vary depending on operating hardware and sash width. The typical open position is approximately 70 to 80 degrees. Full opening can be achieved by pressing the open button repeatedly once the window has stopped.

## To close:

- Press “Close” on either the wall switch or the remote control to close the window.

## To stop the window in an intermediate position:

- Press the opposite button while the motor is running (such as pressing “Close” while the window is opening) will stop the motor. The motor is restarted by pressing either “Open” or “Close” again.

## Status Light Indicator

- During motor operation the status light in the center of the wall plate will be green to indicate normal operation. (See “**Status Codes**” on page 28 for more information.)

# Optional Accessories

## Rain Sensor (included)

---

The sensor will close the window when “beading” moisture is present on the surface of the rain sensor grid. It will also cause the green LED on the wall plate to blink (indicating moisture is present). Once the panel is dry, normal operation is regained.

**Note:**

- *Connect the supplied sensor panel to the grey and green terminals on Block 5 (see main wiring diagram, page 17). The window can be forced to open even when the sensor is “wet” but the motor will immediately re-close the vent.*
- *There is a 10 second delay from the time the rain sensor senses moisture to the time the window actually starts to close.)*

**Rain Sensor Guidelines:**

- Install the sensor with "grid" exposed to outside elements where the rain has a clear, unobstructed path to the rain sensor. Consider prevailing winds.
- Wire with 22 AWG - 2 conductor shielded, twisted pair 50 ft (15m) maximum length

**Warning:** *Connect shield to earth ground to reduce interference from lightning and other electrical devices.*

- The sensor can be mounted outside (maximum sensitivity) or inside vent edge (minimum maintenance)
- Maintenance; Regular cleaning of sensor panel with a mild cleaning agent is recommended. Dirt or debris can cause the vent to stay closed even when rain is not present.

**Warning:**

- *When used on skylights, do not route rain sensor wire through the chain port, damage to wire will be a likely result.*
- *Do not install the rain sensor if venting of the window or skylight using the HPI inputs is more important than closing due to rain. The rain sensor overrides all other inputs. (see HPI, page 22).*

# High Priority Inputs (HPI)

---

The control unit includes inputs to allow window control from other devices such as thermostats, home automation systems, security systems, etc. These inputs are called High Priority Inputs (HPI). There is an input for “Open” and an input for “Close”. The inputs are designed to be controlled with low voltage dry contacts (relay).

**Note:** See main wiring diagram on page 17 for proper connections.

- **Input Function - HPI Close:**

1. When connected by a continuous contact closure, the window will close. All other input devices (except for Open & Hold) will be “locked-out” until the contacts re-open. Do not attempt to open until window is closed otherwise system may become confused.
2. When connected by momentary contact closure, the window will close. There will be a minimum delay of 3 seconds before system will react.

If window is “opening” (in motion) when a momentary “Close” is received, the motor will stop. In this way a partial open position can be achieved.

- **Input Function - HPI Open:**

1. When connected by a continuous contact closure, the window will open. All other input devices will be “locked-out” until the contacts re-open. There will be a minimum delay of 3 seconds before system will react. Do not attempt to close until window is opened otherwise system may become confused.
2. When connected by momentary contact closure, the window will open. There will be a minimum delay of 3 seconds before system will react.

If window is “closing” (in motion) when a momentary “open” is received, the motor will stop. In this way a partial open position can be achieved.

**Important:**

- Voltage supplied by HPI input is: 12 VDC @ 5mA. For reference only.

# System Status Feedback

---

The Sentry II control unit is capable of providing feedback regarding whether the window is closed or not closed. It will not provide true window position other than closed.

**Note:** See main wiring diagram on page 17 for proper connections.

## Status output function:

- The status output functions as a relay. When the output is closed (relay contacts closed), the window is fully closed. When the output is open (relay contacts open), the window is not fully closed.
- Feedback output (contact closure) maximum ratings:

Rated Load:	0.50 A at 125VAC, 1 A at 24VDC
Minimum Load:	1mA, 5VDC
Max. operating voltage:	125 VAC, 60 VDC
Max. operating current:	1A
Max. switching capacity:	62.50 VA, 30W

# Power Blind Control

---

The Sentry II control unit is capable of controlling 24 VDC blinds or shades. AmesburyTruth does not supply power blinds or shades. We only supply a means to conveniently control them with the Sentry II control system. This allows for a more convenient installation by combining the control of power blinds into the same control system that opens and closes the windows. Therefore, it is very important to choose a power blind system that is compatible with the Sentry II control system.

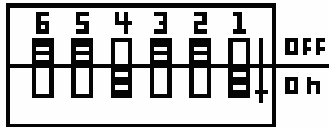
Please use the following electrical specifications:

- Operating Voltage: 24 VDC
- Maximum current draw: 1 amp (at 24 VDC)
- Power blind system must be range protected with internal limit switches.

**Note:** AmesburyTruth does not supply the installation instructions for the installation of the motorized blinds themselves. Please consult instructions supplied with the blinds for installation.

### Control unit setup for Power Blind installation:

- Locate DIP switch block on the control unit labeled “S2”. (See main wiring diagram on page 17.) Set DIP switch #4 to the “on” position.



- Consult blind installation instructions for proper blind motor polarity. Locate the positive wire to open the motorized blind. Connect it to the “Grey” terminal on terminal block #12. (See main wiring diagram.)

#### Note:

- If unable to determine the positive wire to open the motorized blind, the blind motor can be connected in either orientation. However, if the blinds open in the opposite direction from the button pressed, the two wires will need to be reversed.
- When the blinds are used in combination with the HPI “Open” function, the blinds will open automatically before the window is opened. This is because this feature is often used for smoke evacuation when connected to a smoke alarm.

The following companies can provide information on blinds or shades that are compatible with the Sentry II Motor System. **Be sure to ask for the “Motivator” series made by Verosol.** Try these Verosol distributors:

OEM Shades Inc.  
700 First Ave.  
Ford City PA 16226  
724-763-3600  
[www.oemshades.com](http://www.oemshades.com)

Shades Unlimited  
545 Brooklyn Road  
Mount Tabor VT 05739  
802-293-2478  
[www.skylightshades.com](http://www.skylightshades.com)

## Trouble Shooting

### Common Problems

---

#### Motor does not fit the operator

- Check to be sure the operator was manufactured by AmesburyTruth

#### Motor does not run

- Check to make sure power is on
- Check to make sure that either the screen interlock is connected or installed properly. (See page 13.)



- Check to make sure the jumper is installed across the two grey terminals on block 10. (See main wiring diagram on page 17.)

#### **Motor is not straight on my window**

- Check to be sure the correct mounting hole is used in the mounting bracket. (See step 4 on page 12.)

#### **Window closes for unknown reason**

- Check to make sure the rain sensor is clean – debris or bird droppings can activate the rain sensor. Clean with a mild soap.
- The motor system may have closed the windows due to a power outage. Normal operation is to close the windows when the power comes back on.

#### **The window will not open**

- If the window is equipped with manual sash locks make sure they are unlocked.
- Check to be sure the window is not sealed closed against the weather stripping. Some paints and varnishes will stick to weather stripping. If this happens, apply a thin film of automotive finish wax to the finished window surface.

#### **The motor will not respond from the wall switch**

- Verify the connector on the back of the switch is connected properly to the control unit. See step 4 on page 16.

#### **Window closes when “Open” button is pushed (and visa versa)**

- The motor drive direction is incorrect and needs to be reversed. Change setting of DIP switch #3 - See step 5 on page 16.

#### **Window does not open fully**

- The motor system is programmed to only open a window or skylight to 70% of full opening. This is done to protect the hardware from repeated high stresses. Full opening can be achieved by pressing the open button repeatedly once the window has stopped.

#### **The window or skylight will not open more than a couple of inches**

- The control system needs to be re-initialized. Follow “System Reset” procedure below.

#### **When bench testing the motor the motor will not stop**

- This is normal operation. The control unit is looking for a current rise caused by a motor stall to turn the motor off.

#### **Window does not fully close**

- This is usually caused by a motor system that is connected backwards. To correct:
  - Turn the power off;
  - On switch block S2 reverse the position of switch 3 (see main wiring diagram on page 17);
  - Turn power back on;
  - Motor system will automatically run through a reset the first time the

open or close button is pushed.

### Motor system is not functioning as expected

- Interrupting the power to the control unit for a short period of time (approximately 30 seconds) will clear some operating errors. When power is re-applied the unit should close automatically. (Allow window to fully close before giving the motor system an open or close command.) Normal function should be restored.

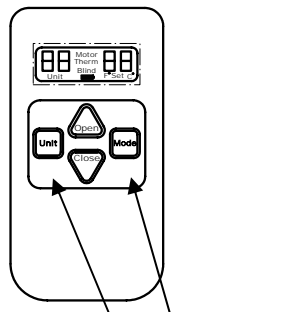
## System Reset

---

There are times when the motor system operating characteristics can change. This can occur for a number of reasons. A couple of examples are if the motor has hit an obstruction or the manual hardware requires cleaning or service. The motor system is designed to recognize unusually high torque situations during operation and then stop short of that area on subsequent operations to protect the motor system and window hardware from damage. If this occurs, the cause of the high torque situation must first be identified and removed. A qualified window service technician may be required. Once the cause has been identified and removed, the window system needs to be re-initialized to restore full range of motion. Follow the “system reset” options below.

There are two different types of resets: **Partial** and **Total**. A partial systems reset will restore normal operation under almost all circumstances and is the easiest to initiate. There are three ways a partial systems reset can be initiated. Power should be cycled off for 30 seconds and back on before attempting any of the reset methods.

- With the window closed, simultaneously press both the window and blind “close” buttons on the wall switch. (See page 20)
- By initiating 3 cycles of open then close (within 3 seconds) via the HPI (See HPI information on page 22)
- First turn power off for 30 seconds then reapply. Then set the remote to the appropriate “Unit Code” and simultaneously press and hold the “Unit” & “Mode” keys down for 10 seconds.



**To “re-initialize” the system:** press and hold these buttons until the “Motor” indicator flashes.

If the operational issue is not resolved with a partial reset as described above a total system reset may be needed.

### **Total System Reset**

1. Turn power off.
2. Change all dip switches to “off” (See S2 on main wiring diagram on page 17)
3. Turn power back on for 30 seconds
4. Turn power off
5. Change dip switches back to proper settings.
6. Turn power back on
7. Push “Open” button on wall switch to open window

## **Service**

---

AmesburyTruth has made every effort to make all pertinent information available to you through this instruction manual and our web site. However, if you encounter a problem or question you can not resolve to please call 1-800-324-4487 to speak to one of our hardware technicians

### **Before contacting AmesburyTruth please be aware that:**

- Contact a qualified window service technician through your window dealer to resolve window or hardware related issues.
- AmesburyTruth is a window and patio door hardware manufacturer. AmesburyTruth is not the manufacturer of your windows.
- AmesburyTruth does not have field service technicians. If you encounter a problem or question you can not resolve to please call 1-800-324-4487 to speak to one of our hardware technicians
- Replacement window hardware is available through the window manufacturer or through one of our authorized distributors.

# Status Codes

---

During setup and operation the status light on the wall plate will provide information regarding system function. The following list will help explain the different conditions indicated:

## **Flashing Red:**

1. Upon initial power-up - This indicates that the dip switches have not been set correctly. See step 5 on page 16.
2. During motor operation – Indicates that the motor has run into an obstruction or that the window hardware requires service. This occurs when the load on the motor exceeds normal operating parameters.

## **Solid Red:**

1. Motor not running
  - Check to be sure jumper is installed. (See block 10 on main wiring diagram.)
  - Check to make sure the screen interlock is connected correctly (if required. (See step 6 on page 13 and main wiring diagram on page 17.)
  - Check motor connections.
2. During motor operation – The motor is running through initialization to learn the range of motion. This is normal operation. The red light will go out once the initialization cycle is completed successfully.

## **Solid Green:**

Indicates normal motor operation. The light will stay green only while the motor is running.

## **Flashing Green:**

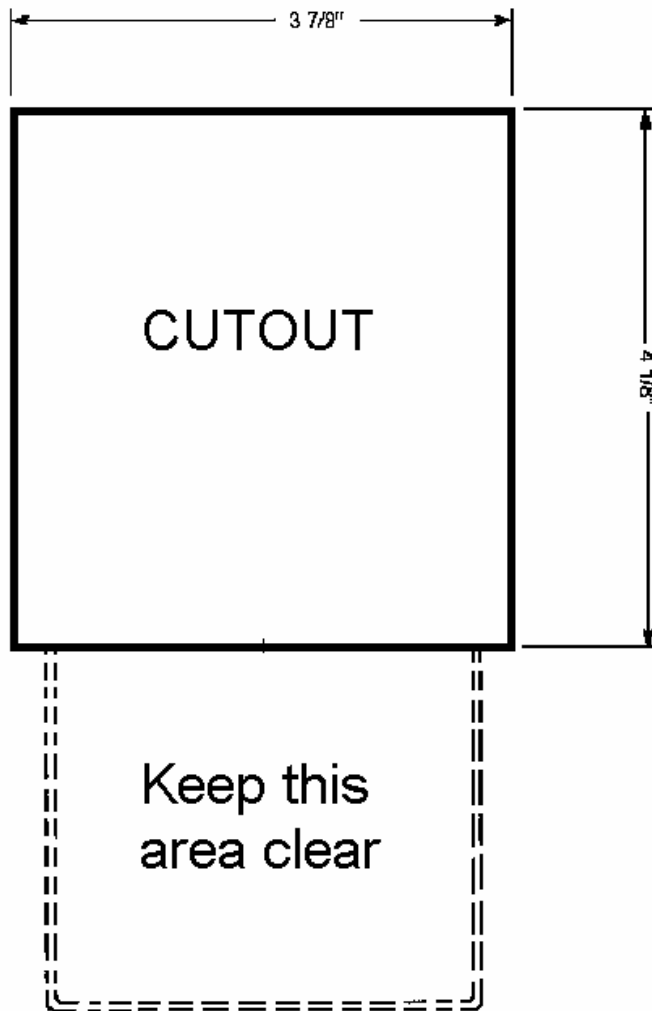
During set-up: Indicates “learn” mode during remote control set-up. Occurs after pressing “S1”. (See Installation Instructions supplied with Remote Control.)

During normal operation: Indicates the rain sensor has been activated. The light will flash green only while the window is closing.

# Control Box Cut-Out Template

---

**Note:** Control box orientation can be rotated to either a horizontal or vertical position to suit installation.



# Regulatory Compliance

## United States of America

### Federal Communications Commission (FCC)

#### Unintentional emitter per FCC Part 15

Note: This equipment has been tested and found to comply with the limits for a Class B digital device, pursuant to part 15 of the FCC Rules. These limits are designed to provide reasonable protection against harmful interference in a residential installation. This equipment generates, uses, and can radiate radio frequency energy and, if not installed and used in accordance with the instructions may cause harmful interference to radio communications. However, there is no guarantee that interference will not occur in a particular installation. If this equipment does cause harmful interference to radio or television reception, which can be determined by turning the equipment off and on, the user is encouraged to try to correct the interference by one or more of the following measures:

- Reorient or relocate the receiving antenna.
- Increase the separation between the equipment and receiver.
- Connect the equipment into an outlet on a circuit different from that to which the receiver is connected.
- Consult the dealer or an experienced radio/TV technician for help.

**Warning:** Changes or modifications not expressly approved by AmesburyTruth could void the FCC compliance and negate your authority to operate the product.

## FCC Declaration of Conformity

### According to 47 CFR, Parts 15.107 and 15.109 Class B

**Responsible party:** AmesburyTruth , 700 West Bridge St., Owatonna, MN 55060  
[www.amesburytruth.com](http://www.amesburytruth.com) or 1-800-324-4487

**Product:** Sentry II Hand Held Remote (43.53)

This device complies with part 15 of the FCC Rules. Operation is subject to the following two conditions: (1) This device may not cause harmful interference, and (2) this device must accept any interference received including interferences that may cause undesired operation.

## Canada

### Industry Canada (IC)

#### Unintentional emitter per ICES-003

This class B digital apparatus complies with Canadian ICES-003.  
Cet appareil numérique de la classe B est conforme à la norme NMB-003 du Canada.

Operation is subject to the following two conditions: (1) this device may not cause interference, and (2) this device must accept any interference, including interference that may cause undesired operation of the device.

## Europe

### European Community EMC Directive (CE)

**Compliance with these directives implies conformity to the following European Norms or Regulations:**

#### Emissions

ETSI EN 300-220-1 v1.3.1 (2000-09)  
ETSI EN 300-220-3 v1.1.1 (2000-09)  
ETSI EN 301 489-3 v1.2.1 (2000-08)  
EN 55014-1: 1997

#### Immunity

ETSI EN 301 489-3 v1.2.1 (2000-08)  
EN 55014-2: 1997

**CONFORMS TO ANSI/UL STD 325; CERTIFIED TO CAN/CSA STD C22.2 NO. 68**